

### 产品特点:

- ✓ 扁平化小体积
- ✓ V 级能效
- ✓ 超低待机功耗<0.4W
- ✓ 300Vac 介电强度
- ✓ 5km 海拔
- ✓ 5G 振动标准
- ✓ 翻盖端子, 双 Y 电容设计
- ✓ 3 年质保

### Features:

- ✓ Ultra compact
- ✓ V class of Energy Star
- ✓ No load power consumption<0.4W
- ✓ 300VAC input surge
- ✓ Operating altitude up to 5000 meters
- ✓ Withstand 5G vibration test
- ✓ Terminal with protection cover and Double Y capacitor design
- ✓ 3 years warranty

### 应用领域:

- ✓ 家电行业
- ✓ 资讯行业
- ✓ 工业控制
- ✓ 生产制造
- ✓ 电气设备
- ✓ 仪器仪表

### Application:

- ✓ Household appliances
- ✓ Information industry
- ✓ Industrial control
- ✓ Production and manufacturing industry
- ✓ Electrical apparatus
- ✓ Instruments and meters

# ESA-100-15

## 产品规格书

## PRODUCT SPECIFICATION

制造安全产品 驱动绿色世界 Power a Safe and Green world

Excellent 卓越 Creative 创造 United 协作



# 合肥华耀电子工业有限公司

ECU ELECTRONICS INDUSTRIAL CO.,LTD.



微信扫码关注

电话 TEL 4006659997/0551-62731110  
传真 FAX +86-551-65324417 转 0

安徽省合肥市蜀山区淠河路 88 号  
No.88 Pihe road P.O BOX 9023-  
20,Hefei China

<http://www.ecu.com.cn>  
<http://www.ecupowersupply.com>  
[sales@ecu.com.cn](mailto:sales@ecu.com.cn)

基本参数 Basic Parameter	1
输入特性 Input Characteristics	1
输出特性 Output Characteristics	2
环境特性 Environment Characteristics	2
保护功能 Protection Function	3
特殊功能 Signals Function	3
电气安全 Electrical Safety	3
电磁兼容 Electromagnetic Compatibility	4
可靠性数据 Reliability	5
结构与安装 Mechanical Installation	5
附件（产品安装示意图、放置示意图、标签图、降额曲线、串联接线图）	6
Appendix(Product assembly/ Standard Mounting/ Label/ Derating Curve/ Series Connection Diagram)	6

## 基本参数 Basic Parameter

项目 Item	单位 UNIT	规格 Specification	备注 Notes
输出电压 Output Voltage	Vdc	15	0%~100%负载
输出电压可调范围 Adjustable range	V	13.5~16.5	0%~100%负载
额定输出电流 Rated current	A	0~6.7	15Vdc
额定功率 Rated power	W	100.5	15Vdc/6.7A
纹波电压 Ripple&noise	mVp-p	100	0%~100%负载

注:输出纹波噪声测试条件 DC output ripple & noise test conditions

1)使用 12 英寸 (300mm) 的双绞线将电源连接至负载, 同时在负载端并联 0.1uF 和 47uF 电容。

12" (300mm) of twisted load cables, paralleled 0.1uF ceramic and 47uF electrolytic placed across the terminals at the load.

2)示波器须设置在 20M 赫兹带宽, 在负载端进行测试。

Scope probe, 20MHz bandwidth-limited, placed across the terminals at the load.

## 输入特性 Input Characteristics

项目 Item	单位 UNIT	最小值 MIN	额定值 Rated	最大值 Max	备注 Notes
输入电压 Input Voltage	Vac	90	230	264	参考输出降额曲线 Refer to output derating curve.
最大介电强度 Maximum dielectric strength	Vac			300	5S最大耐受时间 5S max
输入频率 Input Frequency	Hz		47~63		
输入电流 Input Current	A	/	/	1.2 2.1	230Vac, 满载/230Vac, Full load 115Vac, 满载/115Vac, Full Load.
输入冲击电流 Inrush Current	A	/	/	35 30	230Vac/50Hz, 100%负载, 冷启动 230Vac/50Hz, 100% Load. cold start. 115Vac/60Hz, 100%负载, 冷启动 115Vac/60Hz, 100% Load. cold start
空载损耗 No-load loss	W			0.4	230Vac,空载/No Load.
输入保险 Input Fuse			T4A/250Vac		

## 输出特性 Output Characteristics

项目 Item	单位 Unit	最小值 Min	典型值 Typ	最大值 Max	备注 Notes
效率 Efficiency	%	/	85	/	230Vac/50Hz, 最大负载 230Vac/50Hz, Max Load.
负载调整率 Load Regulation	%	/	+/-1	/	5%~100% 负载 @230Vac/115Vac 5%~100% Load @230Vac/115Vac
输入电压调整率 Line Regulation	%	/	+/-1	/	90~264Vac输入@100% 负载 90~264Vac Input @100% Load
开机延迟时间 Setup Time	s	/	/	2	115Vac或230Vac 输入, 满载 115Vac&230Vac Input Full Load
上升时间 Rise Time	ms	/	/	40	输出从10%上升到90%的时间 The output voltages shall rise from 10% to 90% of their output voltage.
保持时间 Hold time	ms	30	/	/	230Vac 输入, 满载 230Vac Input, Full Load
		12	/	/	115Vac 输入, 满载 115Vac Input, Full Load
过冲响应 Overshoot & undershoot Response	%			+/-5	开关机时 Power on/off
负载动态 Load dynamic response	%	/	/	+/-5	设定周期20ms,升降电流0.1A/us,在50%~100%负载 Settling time 20ms R/s 0.1A/us load 50%~100% Load

## 环境特性 Environment Characteristics

项目 ITEM	单位 UNIT	最小值 MIN	典型值 Rated	最大值MAX	备注 Notes
温度 Temperature	℃	-20	25	70	工作温度Operation Temperature; 参考负载降额曲线 (attached drawing)
		-40	25	85	贮藏温度Storage Temperature
相对湿度 Humidity	%	20%	/	90%	工作湿度Operation Humidity
		10%	/	95%	贮藏湿度Storage Humidity
振动 Vibration	/	GB/T2423.10-2008/IEC 60068-2-6, 正弦10-500Hz, 5G, 位移0.35mm, X、Y、Z轴各60分钟; Sine Wave:10-500Hz, 5G, displacement of 0.35mm; 60 min per axis for all X, Y, Z directions			
冲击 Impact	/	GB2423.5/IEC60068-2-27,半正弦波: 15G, 持续11ms, 每个方向3次, 共6次 Half Sine Wave:15G for a duration of 11ms, 3 times per direction, 6 times in total			
海拔高度 Altitude	M	≤5000			
冷却方式 Cooling Mode		空气自然冷却 Air Cooling			
防护等级 IP level		GB4208-2008 IP20/EN 60529/IEC 529			

## 保护功能 Protection Function

项目 Item	技术要求 Requirement	注释 Notes
短路保护 Short Circuit Protection	电源无损坏, 关闭输出电压 No damage shut down O/P voltage	故障移出后, 电源自动恢复。 Recovers automatically after fault condition is removed
过载保护 Over load Protection	110%~150% @ I <sub>o</sub>	故障移出后, 电源自动恢复。 Recovers automatically after fault condition is removed
过压保护 Over voltage Protection	120%~145% @ V <sub>o</sub>	过压发生后, 必须重新启动才能恢复。 Reset must be need when over voltage to get right.

## 特殊功能 Signals Function

项目 Item	技术要求 Requirement
面板显示 Panel display	电源开启, LED指示灯亮 LED indicator for power on;

## 电气安全 Electrical Safety

项目 Item	测试方法 Test Method	测试条件 Test Conditions
绝缘电压 Withstand voltage	输入-输出 I/P-O/P	1500Vac 50Hz 1 分钟/minute 切断电流≤10mA
	输入-大地 I/P-FG	1500Vac 50Hz 1 分钟/minute 切断电流≤10mA
	输出-大地 O/P-FG	500Vac 50Hz 1 分钟/minute 切断电流≤10mA
绝缘阻抗 Withstand Resistance	输入-输出 I/P-O/P	DC500V 100MΩ分钟/min(at 25℃, 70%RH)
	输入-大地 I/P-FG	DC500V 100MΩ分钟/min(at 25℃, 70%RH)
	输出-大地 O/P-FG	DC500V 100MΩ分钟/min(at 25℃, 70%RH)
泄露电流 Leakage Current	L、N-外壳/L、N-Case	3.5mA Max
	L、N-PE/L、N-PE	3.5mA Max
接地阻抗 PE Resistance	PE-外壳/PE-Case	< 0.10hm
污染等级 Pollution Level	EN50178	2级
设计标准 Design standards	UL508 工业控制类	
	EN60950-1 资讯类	
	UL1310 Class2 类电源	/
	EN60335-1 家电类	/
	EN61347-1 灯具类	/
	IEC60601-1 医疗类	/

1) 标准A: 规格界限内正常性能 Criteria A: Normal performance within the specification limits

2) 标准B: 可自行恢复的临时性退化或功能丧失 Criteria B: Temporary degradation or loss of function which is self-recoverable

3) 不对称: 共模 (线对地) Asymmetrical: Common mode (Line to earth)

4) 对称: 差模 (线对线) Symmetrical: Differential mode (Line to line)

5) ”/”: 不符合项 Non-conformance

# 电磁兼容 Electromagnetic Compatibility

项目 Item	测试方法 Test Method	测试条件 Test Conditions
静电ESD Electrostatic Discharge	IEC 61000-4-2 GB17626-2	Air Discharge: 8kV; Contact Discharge: 4kV. Criteria B
射频辐射RS Radiated Field	IEC 61000-4-3 GB17626-3	80MHz-1GHz, 3V/M, 80% modulation (1kHz). Criteria A
脉冲杂讯EFT Electrical Fast Transient / Burst	IEC 61000-4-4 GB17626-4	AC Power Port + / - 1kV Signal Ports and Telecommunication Ports 0.5kV. Criteria B
雷击 Surge	IEC 61000-4-5 GB17626-5	Common Mode : 2kV; Differential Mode : 1kV. Criteria B
射频传导 Conducted	IEC 61000-4-6 GB17626-6	150kHz-80MHz, 3Vms, 80% modulation (1kHz). Criteria A
电源磁场 Power Frequency Magnetic Fields	IEC 61000-4-8 GB17626-8	1A/Meter. Criteria A
电压瞬断 Voltage Dips and Interruptions	IEC 61000-4-11 GB17626-11	DIPS:5%, 0.5 cycles, Criteria B; 70%, 25 cycles, Criteria C; Interruption: 5%, 250 cycles, Criteria C
低能量脉冲 Low Energy Pulse Test (Ring Wave)	IEC 61000-4-12 GB17626-12	Common Mode : 2kV; Differential Mode : 1kV. Criteria B
谐波 Harmonic Current Emission	EN61000-3-2:2014 GB17625.1	Class A
电磁耐受标准 Immunity Generic Standards		EN 55024,GB17618资讯类
		EN55014-2家电类
	/5)	EN60601-1-2医疗类
	/5)	EN61547灯具类
		EN61000-6-1,EN50082-1,GB/T17799-1轻工业环境 EN 61000-6-2,EN55082-2,GB/T17799-2工业环境
传导和辐射通用标准 CE&RE		GB9254, CISPR 32, EN 55032 : Class B 资讯类
	/5)	GB4824, CISPR 11, EN 55011 : Class B 医疗类
	/5)	GB17743, EN55015, CISPR15: Class B 灯具类
		GB4343-1, CISPR14, EN55014-1: Class B 家电类
		EN 61000-6-3, FCC Title 47, EN55011: Class B 工控类
电压波动和闪烁 Voltage Fluctuation and Flicker		EN61000-3-3:2013 /GB17625.2
测试标准 Supply for General		EN 61204-3

1) 标准A: 规格界限内正常性能Criteria A: Normal performance within the specification limits

2) 标准B: 可自行恢复的临时性退化或功能丧失Criteria B: Temporary degradation or loss of function which is self-recoverable

3) 不对称: 共模(线对地) Asymmetrical: Common mode (Line to earth)

4) 对称: 差模(线对线) Symmetrical: Differential mode (Line to line)

5) ”/ ”: 不符合项Non-conformance

6) 电源应视为系统内元件的一部分, 需结合终端设备进行EMC确认Power should be considered part of the element within the system, to be combined with the terminal device EMC acknowledgment;

## 可靠性数据 Reliability

项目 Item	数据 Data	测试条件 Test Conditions
产品老化 Burn-in	100%	230Va (50Hz), 满载, 40°C, 4小时
平均无故障时间 MTBF	400,000 Hours	230Vac, 100% Load, 25°C, MIL HDBK 217F 230Vac, 满载, 25°C, MIL HDBK 217F
质保 Warranty period	3年	40°C, 230Vac, 80% Load, 24小时工作
设计使用寿命 Design Service life	/	此项依据实际使用条件推算 This calculated based on the actual conditions of use

## 结构与安装 Mechanical Installation

项目 Item	数据 Data	备注 Note
尺寸mm (长宽高) Size	129 * 97.5 * 30	外形尺寸
重量Kg Weight	0.3	
安装方式 Installation	平板式安装 mounted on 35mm DIN rails	
输入端子 Input Terminal	脚距9.5mm, 3位 Pitch=9.5mm, 3pin	最大扭矩1.2N.M 温度范围-40°C~+105°C 横截面 AWG 22 ... 12
	1 PIN---AC(L)	
	2 PIN---AC(N)	
	3 PIN---FG	
输出端子 Output Terminal	脚距9.5mm, 4位/Pitch=9.5mm, 4pin	最大扭矩1.2N.M 温度范围-40°C~+105°C 横截面 AWG 22 ... 12
	4 PIN--- -V	
	5 PIN--- -V	
	6 PIN--- +V	
	7 PIN--- +V	

# ECCU

附件（产品安装示意图、放置示意图、标签图、降额曲线、串联接线图）

Appendix(Product assembly/ Standard Mounting/ Label/ Derating Curve/ Series Connection Diagram)

1. 产品安装示意图 Product assembly

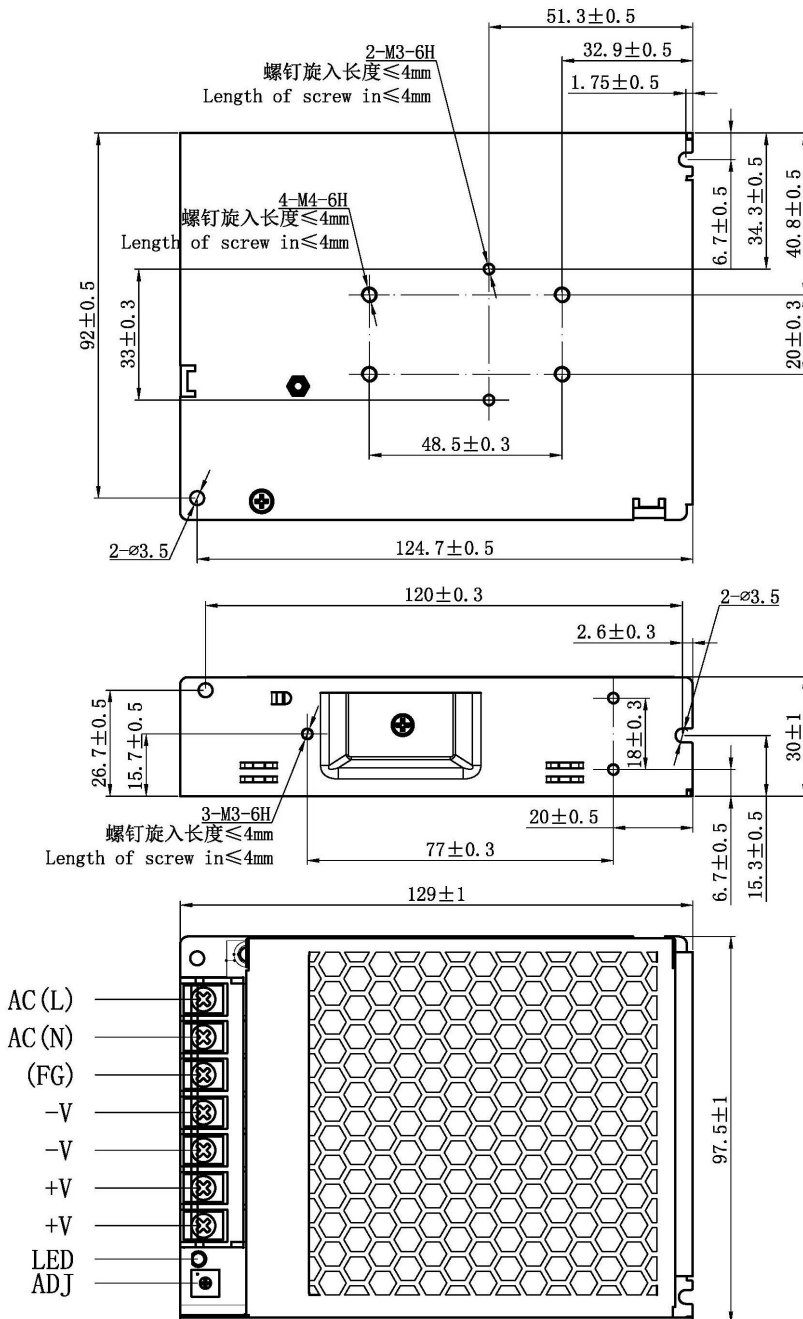

说明:

Introductions:

A: 建议扭矩:M3.0螺钉<0.4 N·m; M4.0螺钉<0.6 N·m。

A:Suggested tightening torque:M3.0 screw < 0.4 N·m;M4.0 screw < 0.6 N·m.



2. 放置示意图 Standard Mounting

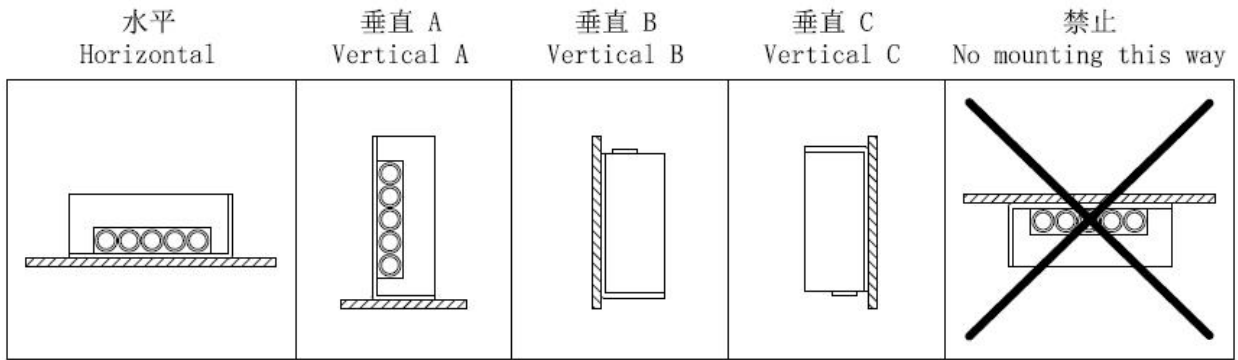

3. 标签图 Label: 略 Ellipsis

4. 降额曲线 Derating curve:

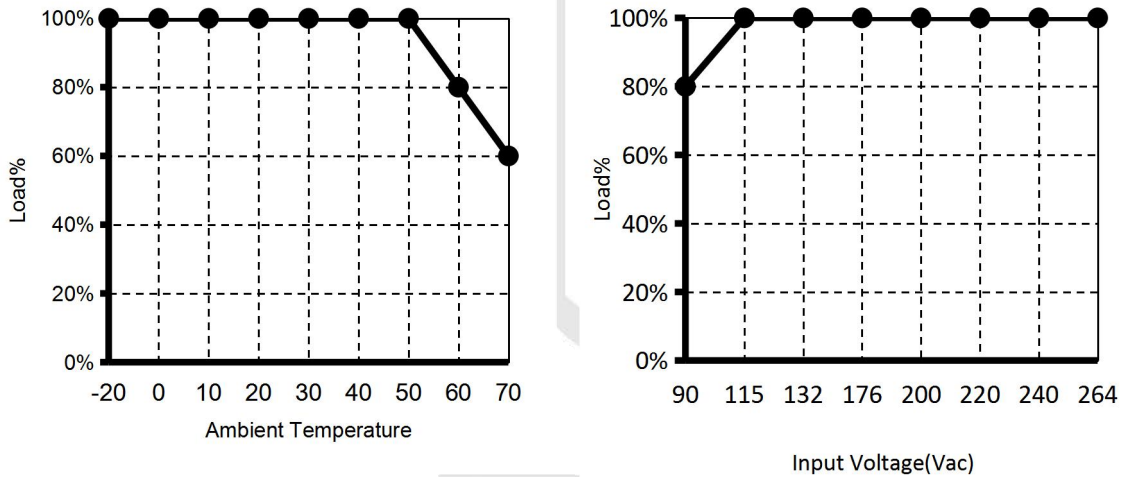

5. 串联接线图 Series Connection Diagram:

